

5-CH BTL DRIVER FOR DVD PLAYER WITH DISC BIDIRECTIONAL DRIVER AND TWO VARIABLE REGULATORS

DESCRIPTION

The SA5888 is a five-channel BTL driver IC for driving the motors and actuators in products such as CD - ROM / DVD drivers. It is also build-in two independent precision voltage regulators with adjustable range from 1.5V to 4V and one channel bi-direction DC motor driver for tray.

www.DataSheet4U.com

FEATURES

- * Wide dynamic range (4.0V (Typ.) when $V_{CC} = 8V$, $PVCC = 5V$, and $R_L = 8\Omega$).
- * Level shift circuit on chip.
- * Thermal shutdown circuit on chip.
- * Mute mode built-in.
- * Two regulator controllers built-in.
- * Five drivers build-in: dual actuator drivers, sled motor driver, spindle driver and tray in-out driver.

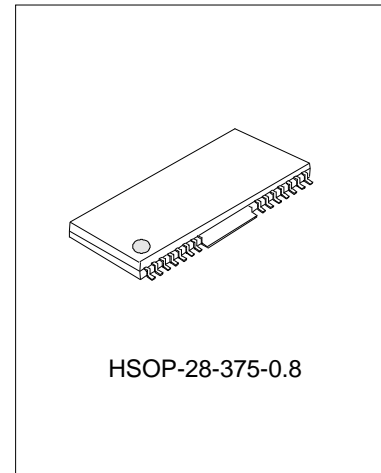

ORDERING INFORMATION

Device	Package
SA5888	HSOP-28-375-0.8

APPLICATIONS

- * CD
- * CD-ROM
- * DVD

BLOCK DIAGRAM

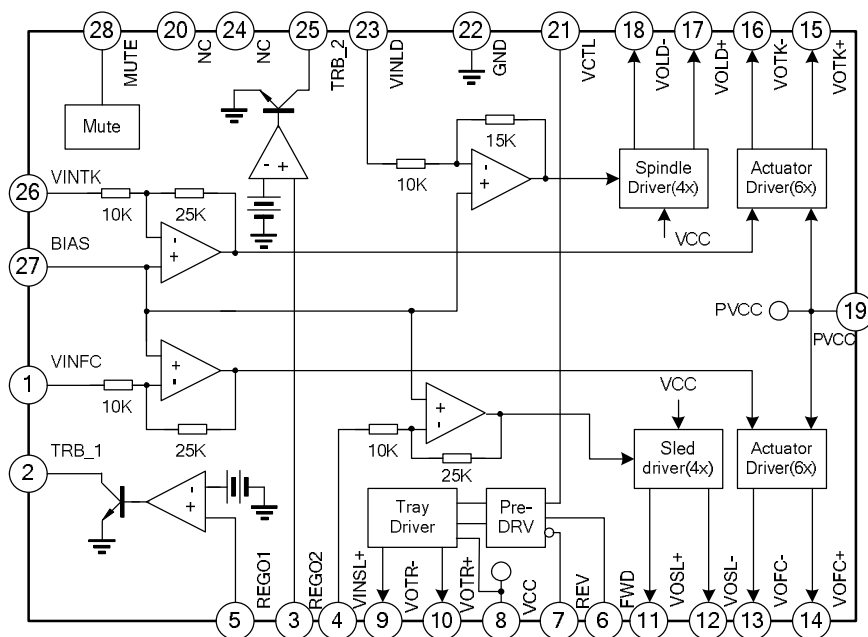

ABSOLUTE MAXIMUM RATINGS (Otherwise specified, $T_{amb}=25^{\circ}\text{C}$)

Characteristics	Symbol	Value	Unit
Power Supply Voltage	VCC, 1/2PVCC	8	V
Power Dissipation	PD	1.7*	W
Operating Temperature	T _{opr}	-35~+85	°C
Storage Temperature	T _{stg}	-55~+150	°C

* When mounted on a 70mm X 70mm X 1.6mm glass epoxy board. Reduced by 13.6mW for each increase in T_{amb} of 1°C over 25°C.

ELECTRICAL CHARACTERISTICS

(Unless other specified, $T_{amb}=25^{\circ}\text{C}$, VCC=8V, PVCC=5V, BIAS=2.5V, R_L=8Ω/10Ω/20Ω/45Ω)

Characteristics	Symbol	Test conditions	Min.	Typ.	Max.	Unit
Quiescent Current	ICC		--	30	--	mA
Actuator Driver						
Output Offset Voltage	V _{oo}		-50	--	50	mV
Maximum Output Amplitude	V _{OM}	10Ω Load	3.6	4.0	--	V
Voltage Gain	G _v	V _{IN} =BIAS ±0.2V	--	23.5	--	dB
Spindle Driver						
Output Offset Voltage	V _{OOFS}		-50	0	50	mV
Maximum Output Amplitude	V _{OMSP}	8Ω Load	--	3.5	--	V
Closed-Circuit Voltage Gain	G _{VSP}	V _{IN} =BIAS ±0.2V	13.3	15.5	17.5	dB
Gain Error By Polarity	ΔG _{VSP}	V _{IN} =BIAS ±0.2V	0	1	2	dB
Sled Driver						
Offset Voltage	V _{OOFSL}		-100	0	100	mV
Maximum Output Amplitude	V _{OMSL}	20Ω Load	7.5	9.0	--	V
Voltage Gain	G _{VSL}	V _{IN} =BIAS ±0.2V	18	20	22	dB
STBY Logic						
STBY On Voltage	V _{STBY1}	All Channels Off	0	--	0.5	V
STBY Off Voltage	V _{STBY2}	All Channels On	2.0	--	--	V
Tray Motor Driver						
Output Saturation Voltage 1	V _{SAT1}	Upper + Lower saturation, I _L =200mA	0.7	1.1	1.5	V
Output Saturation Voltage 1 Between F&R	ΔV _{SAT1}	Output saturation voltage 1 between FWD and REV	-	-	0.1	V
Output Saturation Voltage 2	V _{SAT2}	Upper + Lower saturation, I _L =500mA	1.0	1.55	2.2	V
Output Adjustable Gain On "H" Side Voltage	V _{VtrH}	V _{CTR} =2V	7.4	9.2	11	dB

(To be continued)

(Continued)

Characteristics	Symbol	Test conditions	Min.	Typ.	Max.	Unit
Tray Motor Driver Input Logic						
High Level Input Voltage	V_{IH}		1.5	-	V_{CC}	V
Low Level Input Voltage	V_{IL}		-0.3	-	0.5	V
High Level Input Current	I_{IH}	$V_{FWD}=V_{REV}=5V$	-	180	270	μA
Regulator						
Output Voltage	V_{reg}	$I_L = 500mA$ ②	1.5	--	4.0	V
Output load differential	ΔV_{RL}	$I_L = 0\sim 500mA$ ③	-50	-0	50	mV
Power supply voltage differential	ΔV_{VCC}	($V_{CC}=4.5\sim 8V$) $I_L = 500mA$	-25	0	25	mV

① This device is not designed for protection against radioactive rays;

② It is based on 8550C PNP application;

③ It is based on 8550D PNP application.

PIN CONFIGURATIONS

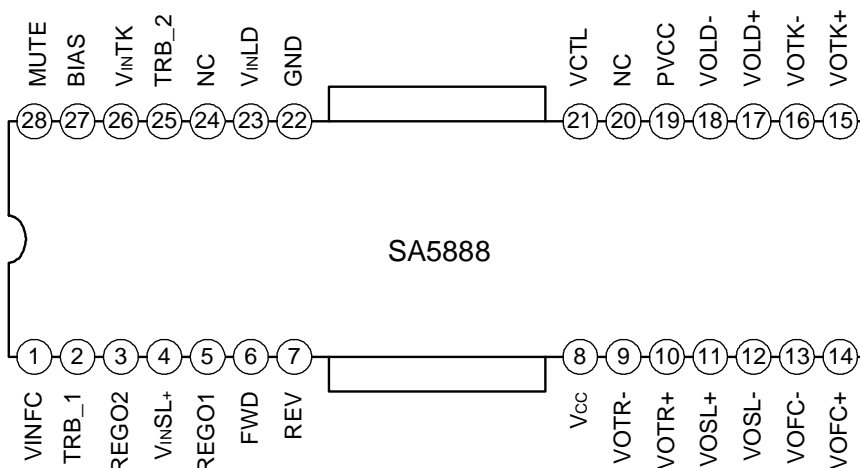

PIN DESCRIPTIONS

Pin No.	Pin Name	Description
1	VINFC	Focus driver input
2	TRB_1	Connect to external transistor base
3	REGO2	Regulator voltage output, connect to external transistor collector
4	VINSL+	Sled driver input
5	REGO1	Regulator voltage output, connect to external transistor collector
6	FWD	Tray driver forward input
7	REV	Tray driver reverse input
8	VCC	VCC

(To be continued)

(Continued)

Pin No.	Pin Name	Description
9	VOTR-	Tray driver output(-)
10	VOTR+	Tray driver output(+)
11	VOSL+	Sled driver output (+)
12	VOSL-	Sled driver output (-)
13	VOFC-	Focus driver output (-)
14	VOFC+	Focus driver output (+)
15	VOTK+	Tracking driver output (+)
16	VOTK-	Tracking driver output (-)
17	VOLD+	Spindle driver output (+)
18	VOLD-	Spindle driver output (-)
19	PVCC	Vcc for power block of spindle, tracking and focus
20	NC	No connection
21	VCTL	Speed control input of tray driver
22	GND	Ground
23	VINLD	Spindle driver input
24	NC	No connection
25	TRB_2	Connect to external transistor base
26	VINTK	Tracking driver input
27	BIAS	Bias input
28	MUTE	Mute control

Notes: The indicated polarities for the output pins are means polarity to inputs.

Always ensure that $V_{CC} \geq PVCC$

FUNCTION DESCRIPTION

Operation notes

- 1) This IC has a built in thermal shutdown circuit that mutes the output current when the chip temperature reaches 135°C (typ.). The hysteresis is set to 25 °C (typ.), so the driver circuits start up again when the chip temperature falls to 120°C (typ.).
- 2) The driver buffer is switched off when the supply voltage falls below 3.6V (typ.), and is switched back on when the voltage reaches 3.8V (typ.) again.
- 3) Bias pin (pin27) should be pulled up to more than 1.2V. In case the bias pin voltage is pulled down below 0.9V (Typ), the output current is muted.
- 4) The stand by circuit logic is active low.
- 5) Mute is applied when the buffer pin voltage falls below 1.0V (typ.). Normally, operate with this pin at 1.8V at least.
- 6) Connect a bypass capacitor between the bases of the power supply pins of this IC.
- 7) Tray driver logic input:

FWD(pin6)	REV(pin7)	VOTR+(pin10)	VOTR-(pin9)	Function
L	L	OPEN	OPEN	Open mode
L	H	L	H	Reverse mode
H	L	H	L	Forward mode
H	H	L	L	Brake mode

The design of 6,7 pin, consider the driver upper and lower unable ducting at the same time, be sure to do it, the motor forward and reverse input by the open mode, and the interval of the open mode is more than 10ms.

Output high level voltage (VOL+, VOL-) ,varied with the motor controller, it can output 3 times voltage of 21pin, and in high level. In this time, the low level voltage input power pipe as the output saturation voltage.

ELECTRICAL CHARACTERISTICS CURVES

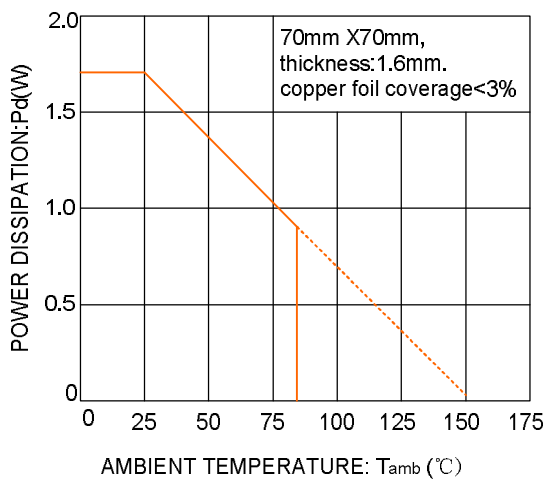

Fig 1. Thermal dissipation curve

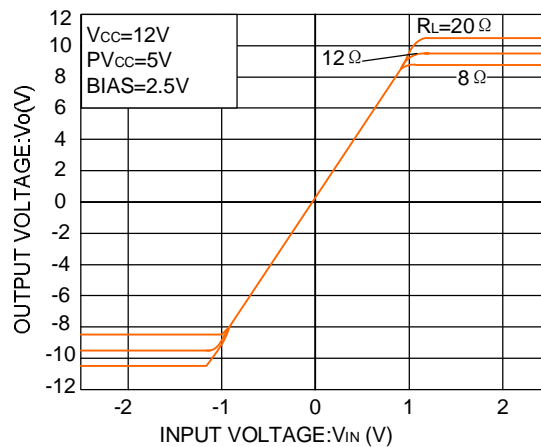

Fig 2. Driver I/O characteristics (Spindle)

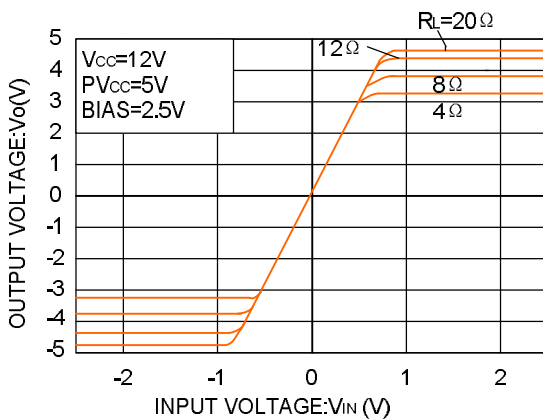
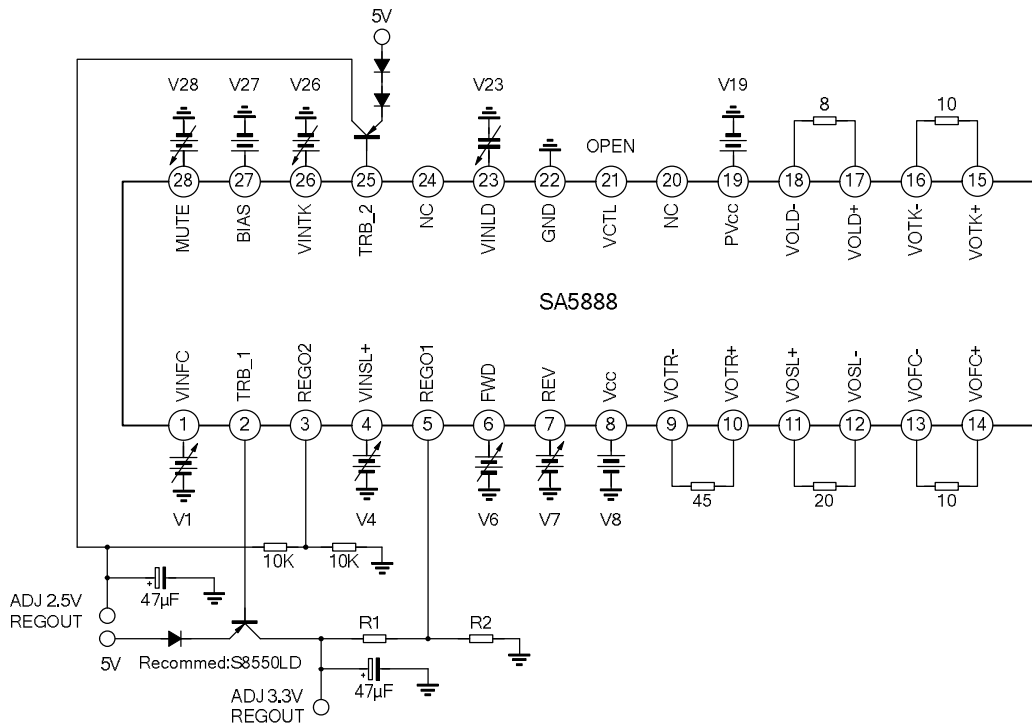
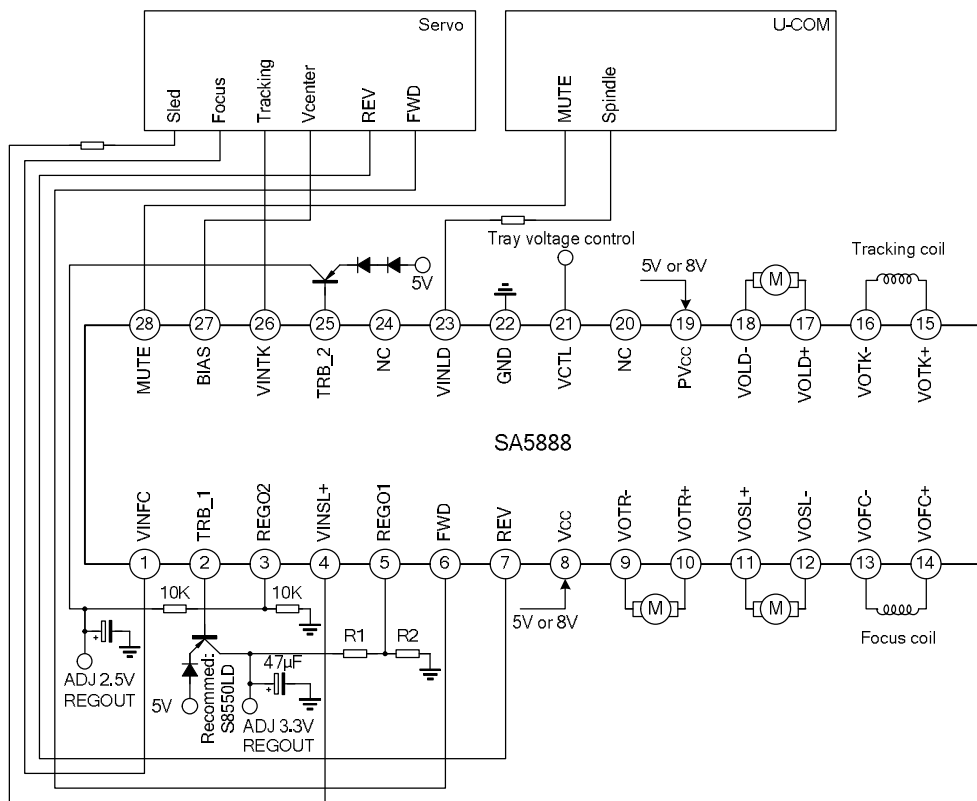

Fig 3. Driver I/O characteristics (sled)

TEST CIRCUIT



TYPICAL APPLICATION CIRCUIT



Note: the value of R1 and R2 in testing circuit and typical application circuit is as the following table:

Solution	SA5888 R1 and R2 are:
卓然	24K and 15K
凌阳	24K and 15K
MTK	20K and 12K

PACKAGE OUTLINE

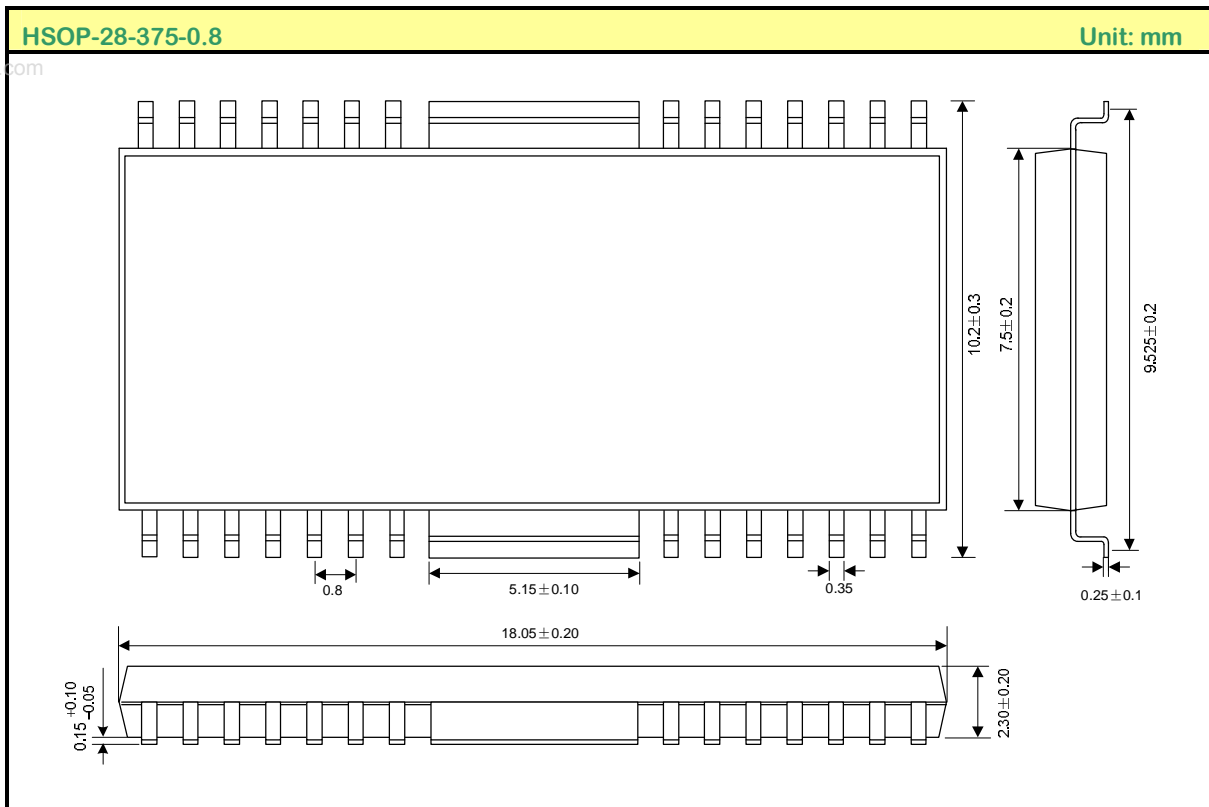



Attachment

Revision History

Data	REV	Description	Page
2005.04.22	1.0	Original	
2006.10.31	1.1	Modify the "TEST CIRCUIT" and "TYPICAL APPLICATION CIRCUIT"	

www.DataSheet4U.com